



ML Solo 1

Technical information

TD030US | 05.12.07

Humidification unit for small spaces and low ceiling heights. Ideal for 'quiet' areas. Offers a low noise level and the same capacity as traditional compressed-air nozzles.

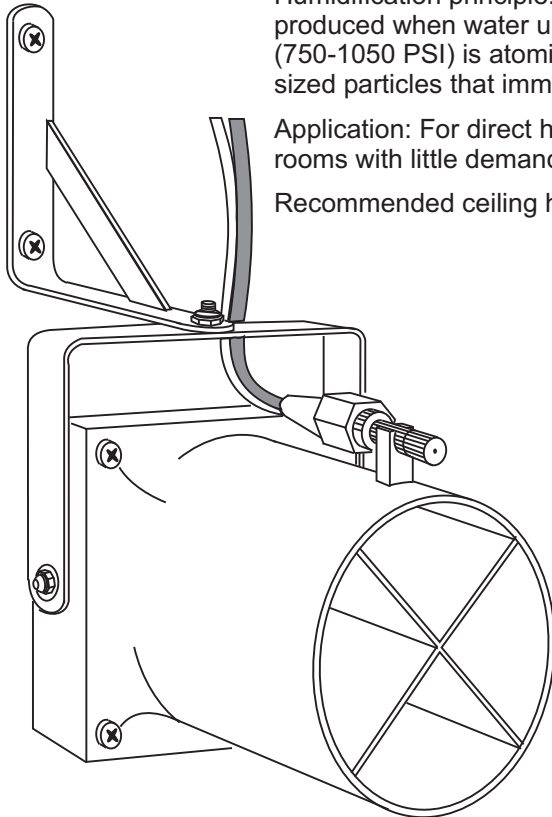

Humidification principle: The humidity is produced when water under high pressure (750-1050 PSI) is atomized into micron-sized particles that immediately evaporate.

Application: For direct humidification and rooms with little demand.

Recommended ceiling height: 8'.

Wall mounting bracket

#132.400

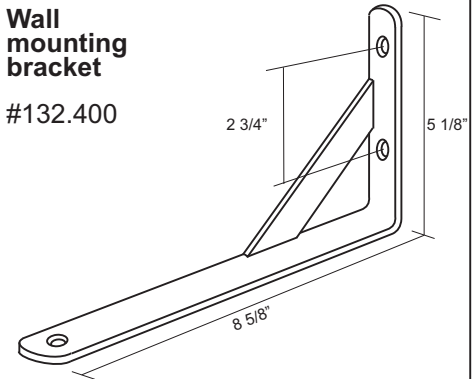

Ceiling mounting bracket

132.401

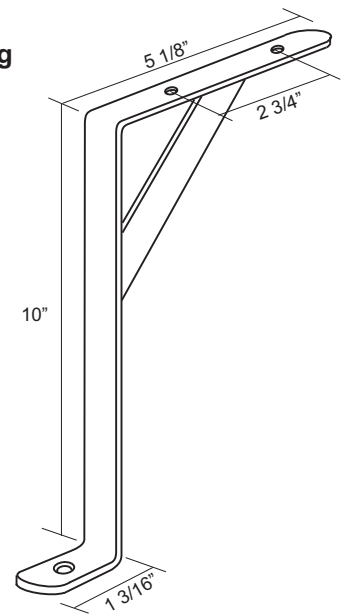

Technical Data

Weight:	Approx. 2.2 lbs.
Size (L x W x H):	6 5/16" x 4 3/4" x 4 3/4" (4 1/4")
Installation:	Ceiling or wall mount
Material:	Powder finished steel
Water connection:	1/8" ML hydraulic hose
Electrical connection:	Must be connected to approved switch . The unit is delivered with 6.5' wire 2 conductor cord 18 gauge
Fan:	Costec type A12 B05 HTB 24 VAC, 50/60Hz, 15/16W
Air capacity:	75 CFM
Humidity capacity:	5.5 - 10 lbs/hr
Noise level:	34/37 dB (A)
MTBF:	50,000 hours
Approval (fan)	UL, CSA, CE, VDE
Min. Distance from nozzle:	10'
Accessories:	Wall bracket #132.400 or ceiling bracket #132.400